

MODEL 200 HYDRAULIC CLAMP

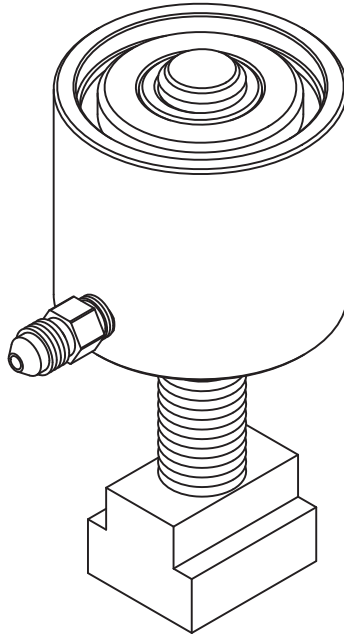

The Model-200 Clamp generates 10,000 of clamping force at 5,000 psi. It is used with dies having slotted underplates, "ears" or "pockets" in line with T-Slots.



N118 W18251 Bunsen Drive
Germantown, WI 53022
(262) 250-4410 • Fax (262) 250-4409

pfa-inc.com

TABLE OF CONTENTS

- 1. Installation 3
- 2. Operation 3
- 3. Maintenance 4
- 4. Seal Replacement Procedure 4
- 5. Recommended Spare Parts 4
- 6. Drawings 5
 - DWG-200
 - DWG-200PD
 - DWG CLAMPSAFE-1
 - DWG CLAMPSAFE-3
 - DWG-392

WARNING

USE SAFETY GEAR AT ALL TIMES – SYSTEM MAY EJECT HYDRAULIC FLUID AT ANY TIME. Read this complete User Guide and study Drawings 200, 200PD, CLAMPSAFE-1, CLAMPSAFE-3 and-392 before proceeding.

Hydraulic plumbing on press/machine depends on the type of clamps used, hydraulic clamping safety employed and other devices, which are connected to the system. Determination of application Safety and Safe Operation is the user’s responsibility.

INSTALLATION

1. Place T-Nut in T-Slot and make sure that the T-Nut is sized correctly.

2. Verify that the stud length is correct.

3. Rotate the stud so that the proper die grip height is achieved. The stud must be fully engaged in the clamp.

Study DWG-200 attached carefully. Make sure that the die grip height for the various dies are within the dimensions noted on DWG-200.

4. Study DWG CLAMPSAFE-1 and CLAMPSAFE-3. They show how hydraulic circuits can be configured. Select the optimum clamping safety for the application.

Note: Double Acting valves, also known as the "Pilot Circuit" option, are designated by PC in the Pump Module part number. Example: 130S-DL-PC2. The pilot circuit is needed for each zone to release the check for clamp opening, when check valves are used.

5. Place the clamp in the T-Slot and connect hydraulic hose. Note that the hydraulic hose will prevent the clamp from rotating. (If the clamp is rotated then the clamping height is changed).

CAUTION: Use a hydraulic pump with a hydraulic pressure sensor to power the clamps. Connect the pressure sensor to press controls to stop the press in the event of hydraulic pressure loss.

OPERATION

Note: Integrate the following steps into your die exchange procedure.

1. **TO INSTALL DIE.** Activate Lift of Die Lifters (if any), Place die in press, and lower die lifters (if any).

2. Move bolster mounted clamps to proper clamping position and activate the proper hydraulic circuit to clamp lower clamps.

3. Make required adjustments and move slide down to upper die.

4. Move ram mounted clamps to proper clamping position and activate the proper hydraulic circuit to clamp upper clamps.

5. Ensure all clamps secure and do not exceed the piston travel for proper clamping preload (Note 10 on clamp drawing).

6. Lock controls to clamps to prevent unclamping.

7. **TO REMOVE DIE,** move slide to proper down position for die exchange.

8. Unlock controls and release hydraulic pressure to all clamps by turning off hydraulic pressure (valves to release).

9. Move clamps away from die.

10. Jog ram up.

11. Activate die lifters, if any.

12. Perform die exchange.

CAUTION: Use only dies with U slots, "ears" or pockets, i.e., clamping surfaces which support the clamp on opposite sides of the stud. Make sure that the clamp surface thickness/die grip height is within the recommended range/adjustment of the clamp (See Drawing 200).

MAINTENANCE

1. Periodically check hoses for signs of wear.
2. Replace hoses if necessary.
3. Examine clamp for damage.
4. Chase any damaged threads if necessary.
5. Check for hydraulic leaks. Tighten fittings or replace hoses as necessary.
6. See enclosed for seal replacement procedures.
7. If a pipe thread fitting is removed, apply new thread tape before reassembling fitting.
8. If stud is replaced, use grade B7 threaded Rod or Forged High Strength Alloy Steel with Minimum Tensile strength 125,000 psi or grade 8 or similar. PFA replacement parts are recommended for proper operation.
9. If T-nut is replaced make sure that it is securely fastened to the stud. Apply permanent thread locking compound IAW manufacturer's recommendations and/or pin T-nut securely in place, if applicable.

SEAL REPLACEMENT PROCEDURE

1. Obtain copy of drawing 200PD, copy attached. Note position of all components.
2. If seals are to be replaced obtain the two seals, retaining ring and lubricant specified on drawing 200PD.
3. If Connector, P/N 1804-1 is removed, apply teflon thread tape before re-installation. Apply proper pipe fitting torque.
4. To disassemble clamp start by removing P/N 3687 retaining ring.
5. Separate the piston from the housing. Place the clamp housing in a soft jaws vise and pull the piston out. (Thread a stud into the piston and pull the assembly out).
6. Remove spring retainer, spring guide and spring as shown in drawing 200PD.
7. Remove the two seals and discard.
8. Clean parts if required.
9. Apply magna-lube in seal (O'ring) grooves and on the seals.
10. Carefully install seals on piston as shown Page 2 of drawing 200PD. The seals must be oriented as shown.
11. Carefully insert piston into clamp housing. Be careful to avoid seal damage.
12. Install spring guide, springs and spring retainer as shown in drawing 200PD.
13. Install new retaining ring. Make sure that the retaining ring is fully seated in groove.
14. Apply hydraulic pressure and check for leaks.

RECOMMENDED SPARE PARTS

1. Hoses connected to clamps.
2. P/N 200PD-SEAL Replacement Kit
3. Stud/T-nut assembly

DISCLAIMER: Illustrative drawings, CAD models, and information described herein is proprietary intellectual property of PFA, Inc., accurate to the company's knowledge at time of printing, and intended for reference only. Specifications are subject to change without notice. If the information obtained from this document is critical to a specific application, it should be confirmed by contacting PFA, Inc. PFA Terms of Sale apply.

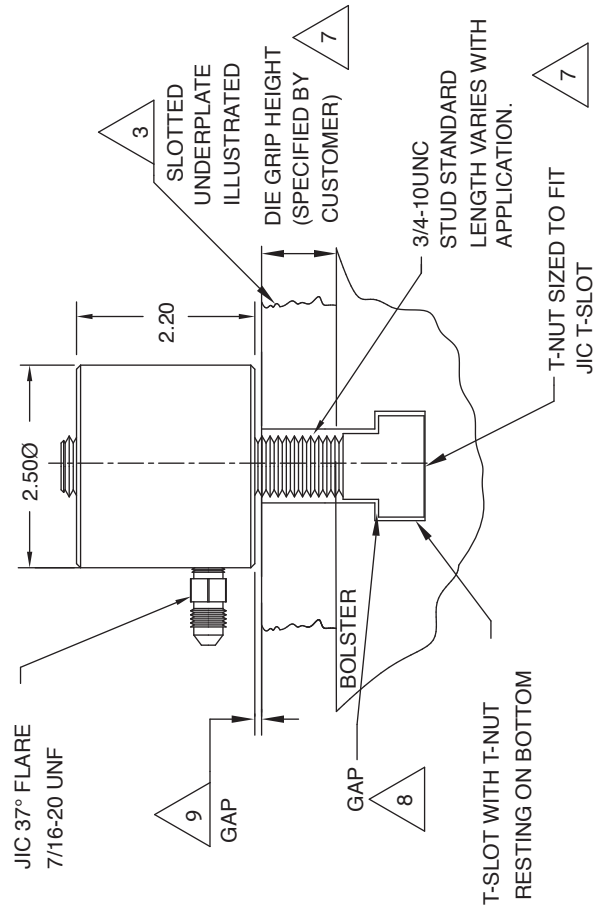
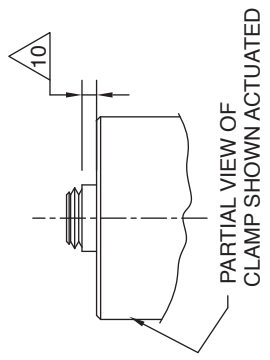
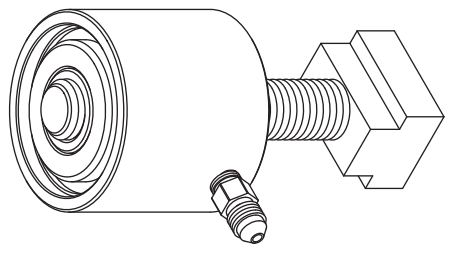

- 8. THE T-NUT SHOULD BE SIZED TO MINIMIZE THIS GAP YET ALLOW THE CLAMP TO MOVE FREELY IN THE T-SLOT.
- 7. T-SLOT SIZE AND GRIP HEIGHT (PROVIDED BY CUSTOMER) WILL BE CONSIDERED WHEN DETERMINING STUD LENGTH. CHANGE TO A LONGER (GRADE 8) STUD IF DIE GRIP HEIGHT PREVENTS THE STUD FROM FULLY ENGAGING THREADS IN THE CLAMP. REPLACEMENT STUD/T-NUT ASSEMBLIES ARE AVAILABLE FROM PFA, INC.
- 6. CLAMP IS SUPPLIED WITH STUD AND T-NUT. PERMANENT THREAD LOCKING COMPOUND AND STAKING IS USED TO PREVENT THE STUD FROM ROTATING IN THE T-NUT
- 5. CLAMP IS OPENED BY INTERNAL SPRINGS AND IS ILLUSTRATED IN THE OPEN (UNPOWERED) POSITION. THE STUD SHOULD BE THREADED INTO THE CLAMP SO THAT IT IS AT LEAST FLUSH WITH THE TOP OF THE CLAMP. NOTE THAT THE STUD PROTRUDES SOMEWHAT ABOVE THE CLAMP BODY IN THE ABOVE ILLUSTRATION.
- 4. AVAILABLE WITH MECHANICAL LOCK (MODEL-200L).
- 3. USE WITH DIES HAVING 'EARS', 'POCKETS' OR SLOTTED UNDERPLATES.
- 2. CLAMPING FORCE: 10,000 LBS. @5,000 PSI.
- 1. OPERATING PRESSURE: 5,000 PSI MAX.
NOTES: UNLESS OTHERWISE SPECIFIED

- 10. THIS DIMENSION SHOWS THE AMOUNT OF PISTON TRAVEL WHICH WAS NECESSARY TO PRELOAD THE STUD TO 10,000 LBS. CLAMPING FORCE. THIS DIMENSION MUST NOT EXCEED .20 WHEN CLAMP IS FULLY ACTUATED.
- 9. ALWAYS KEEP THE GAP BETWEEN THE DIE AND THE CLAMP BODY TO A MINIMUM. (IF NECESSARY REMOVE THE CLAMP FROM THE T-SLOT AND SCREW THE STUD INTO THE CLAMP FOR A CLOSE FIT). THE CLAMP STROKE WHICH IS .29 MUST BE SUFFICIENT TO CLOSE THE GAP/8 AND 9 AND PRE-LOAD THE STUD TO 10,000 LBS OF CLAMPING FORCE.



200 HYDRAULIC NUT
ITEM 200
PAGE 1 OF 1
REV -

CONFIDENTIAL: The information shown on this sheet is confidential. Permission to use, reproduce or transmit in any way not specifically authorized is expressly withheld.

DISCLAIMER: Illustrative drawings, CAD models, and information described herein is proprietary intellectual property of PFA, Inc., accurate to the company's knowledge at time of printing, and intended for reference only. Specifications are subject to change without notice. If the information obtained from this document is critical to a specific application, it should be confirmed by contacting PFA, Inc. PFA Terms of Sale apply.

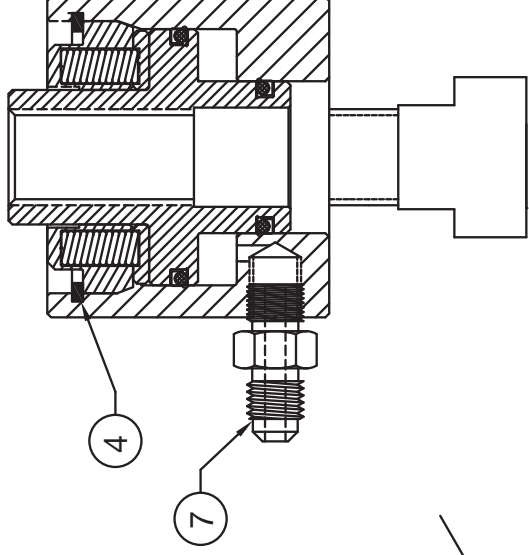
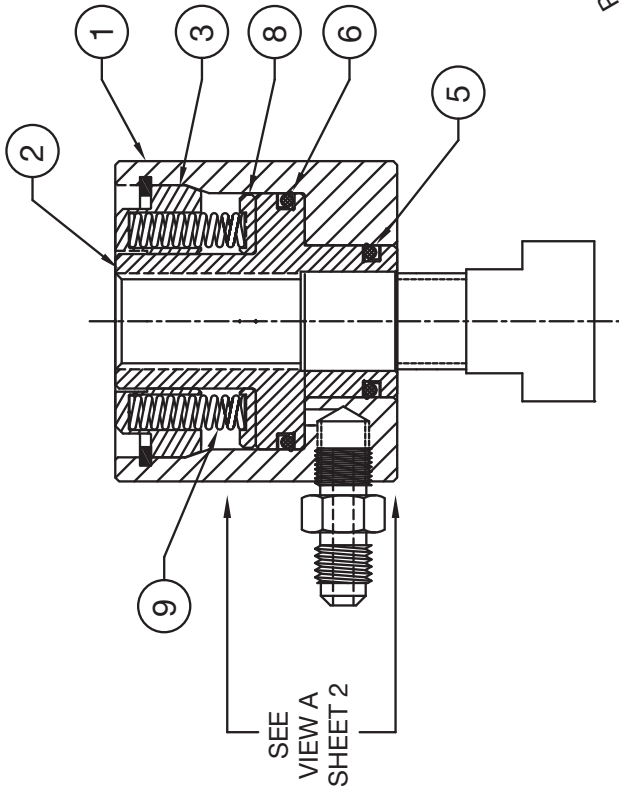

PART# NS2000
PART# NS2000

QTY	SEAL	QTY	QTY	PART NUMBER	DESCRIPTION	ITEM
1	3	1	1	200UG	USERS GUIDE	11
1	1	-	1	ZZ36120	MAGNALUBE, TUBE (NOT SHOWN)	10
-	-	8	8	3716	SPRING, COMPRESSION, .258Ø	9
-	-	1	1	3715	SPRING GUIDE	8
-	-	1	1	1804-1	FITTING, 1/8 MALE, 37°	7
1	1	1	1	3701 PI92001	HIGH PRESSURE SEAL, 2.00 OD	6
1	1	1	1	3700 PI92000	HIGH PRESSURE SEAL, 1.18 OD	5
1	-	1	1	3687 RG00070	RETAINING RING, SPIRAL, 1.18 OD	4
1	-	1	1	3683 NK00021	SPRING RETAINER	3
1	-	1	1	5446 NK00011	PISTON, HYD NUT, 200 SERIES	2
-	-	1	1	5447	HOUSING, HYDRAULIC NUT	1

5 APPLY MAGNA-LUBE 'G' TO SEALS AND MOVING PARTS WHEN ASSEMBLING.

4 NOTE SEAL ORIENTATION (CRITICAL) (SEE SHEET 2)

3 THIS COLUMN SHOWS PARTS INCLUDED IN REFURBISH KIT (PART# 200PD-RFB)

2 THIS COLUMN SHOWS PARTS INCLUDED IN SEAL KIT (PART# 200PD-SEAL)

1 THIS COLUMN SHOWS PARTS INCLUDED IN BASIC MODEL-200 CLAMP (REFERENCE ONLY)



200PD HYDRAULIC NUT

ITEM 200

PAGE 1 OF 2

REV -

CONFIDENTIAL: The information shown on this sheet is confidential. Permission to use, reproduce or transmit in any way not specifically authorized is expressly withheld.

DISCLAIMER: Illustrative drawings, CAD models, and information described herein is proprietary intellectual property of PFA, Inc., accurate to the company's knowledge at time of printing, and intended for reference only. Specifications are subject to change without notice. If the information obtained from this document is critical to a specific application, it should be confirmed by contacting PFA, Inc. PFA Terms of Sale apply.

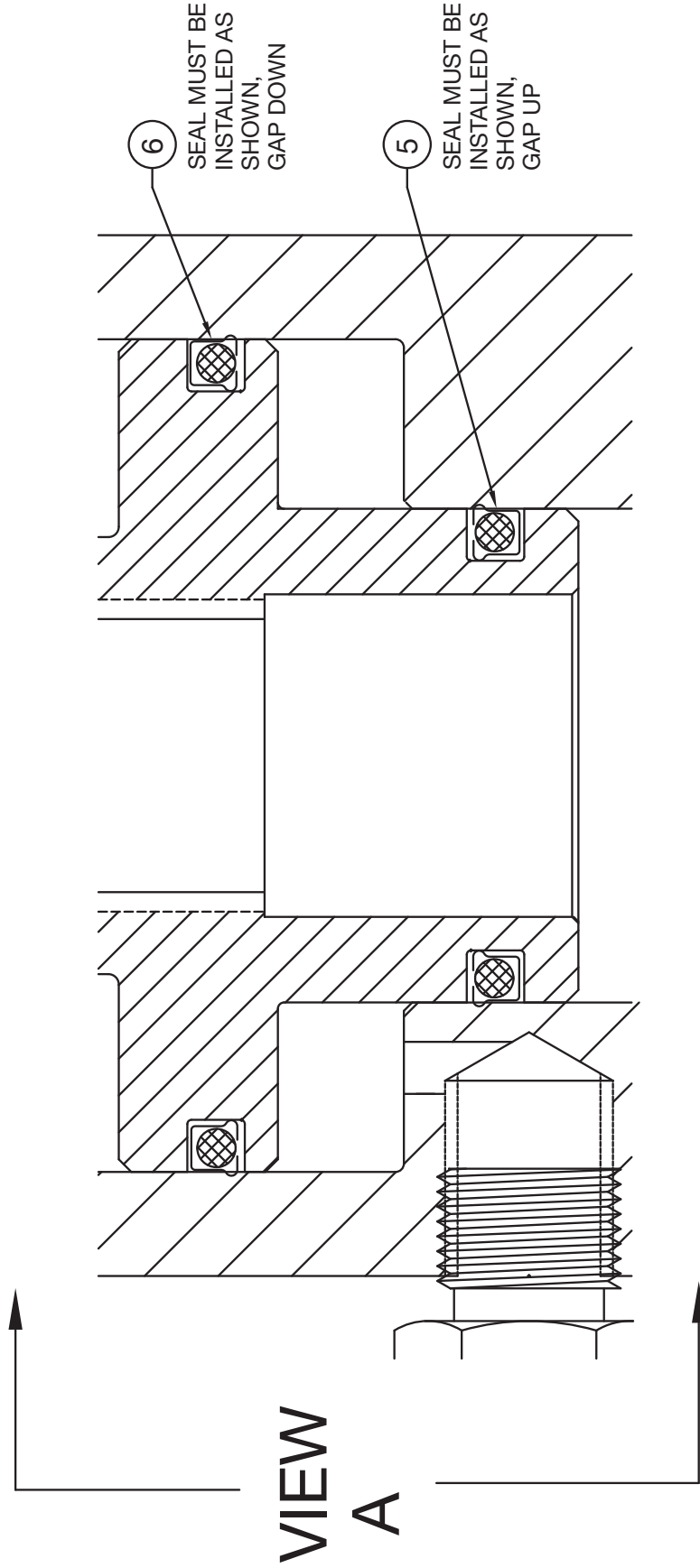

200PD HYDRAULIC NUT

ITEM 200

PAGE 2 OF 2

REV -

CONFIDENTIAL: The information shown on this sheet is confidential. Permission to use, reproduce or transmit in any way not specifically authorized is expressly withheld.

DISCLAIMER: Illustrative drawings, CAD models, and information described herein is proprietary intellectual property of PFA, Inc., accurate to the company's knowledge at time of printing, and intended for reference only. Specifications are subject to change without notice. If the information obtained from this document is critical to a specific application, it should be confirmed by contacting PFA, Inc. PFA Terms of Sale apply.

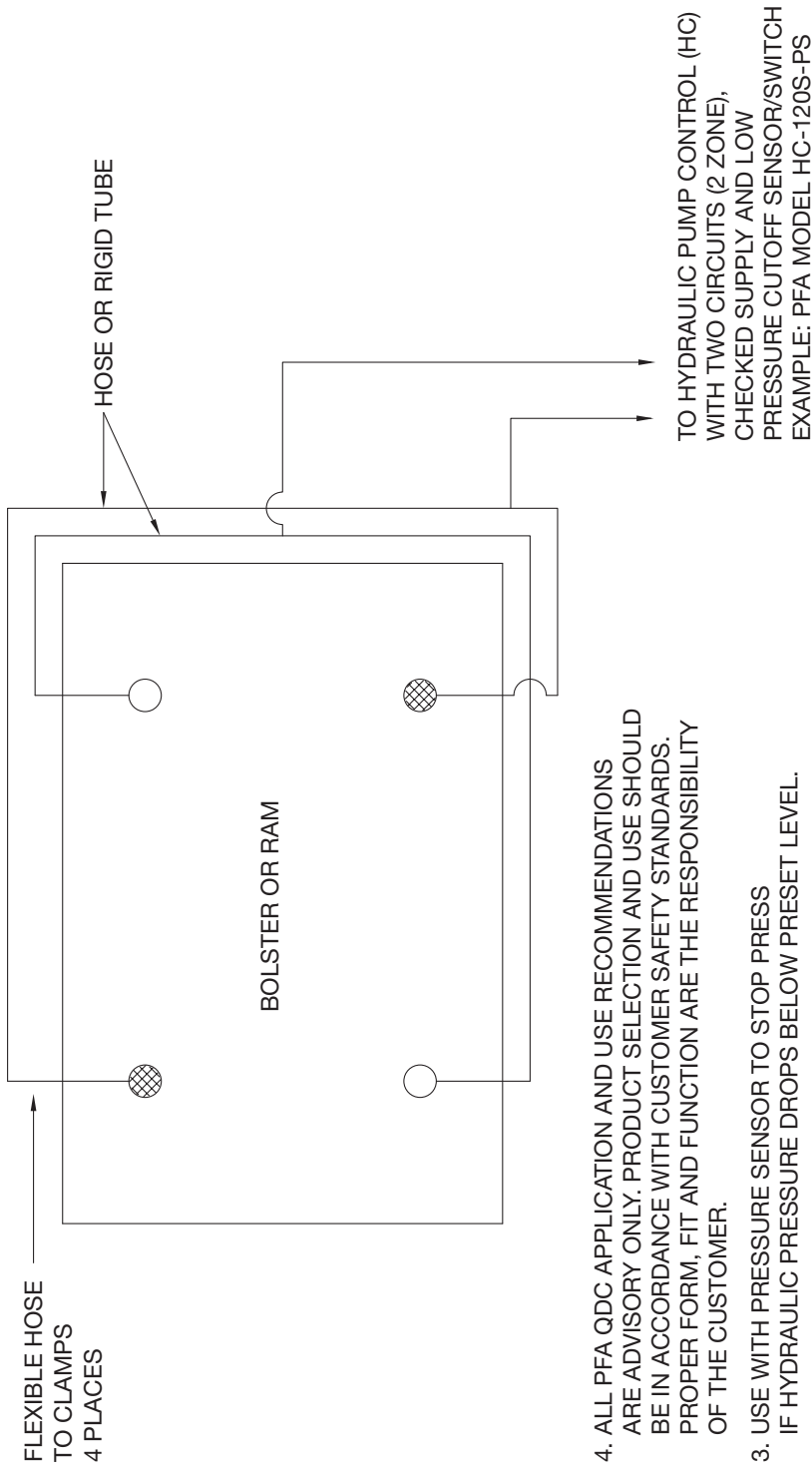

4. ALL PFA QDC APPLICATION AND USE RECOMMENDATIONS ARE ADVISORY ONLY. PRODUCT SELECTION AND USE SHOULD BE IN ACCORDANCE WITH CUSTOMER SAFETY STANDARDS. PROPER FORM, FIT AND FUNCTION ARE THE RESPONSIBILITY OF THE CUSTOMER.
3. USE WITH PRESSURE SENSOR TO STOP PRESS IF HYDRAULIC PRESSURE DROPS BELOW PRESET LEVEL.
2. HYDRAULIC CHECK VALVE LOCATED AT CONTROL VALVE FOR EACH CIRCUIT.
1. CLAMPS POWERED BY INDEPENDENT DIAGONALLY OPPOSITE HYDRAULIC CIRCUITS (ZONES). LOSS OF PRESSURE IN ONE CIRCUIT DOES NOT AFFECT THE OTHERS.

NOTES: UNLESS OTHERWISE SPECIFIED



CLAMPSAFE 1

HYDRO CIRCUITS
DIAGONAL

PAGE 1 OF 3

REV
-

CONFIDENTIAL: The information shown on this sheet is confidential. Permission to use, reproduce or transmit in any way not specifically authorized is expressly withheld.

DISCLAIMER: Illustrative drawings, CAD models, and information described herein is proprietary intellectual property of PFA, Inc., accurate to the company's knowledge at time of printing, and intended for reference only. Specifications are subject to change without notice. If the information obtained from this document is critical to a specific application, it should be confirmed by contacting PFA, Inc. PFA Terms of Sale apply.

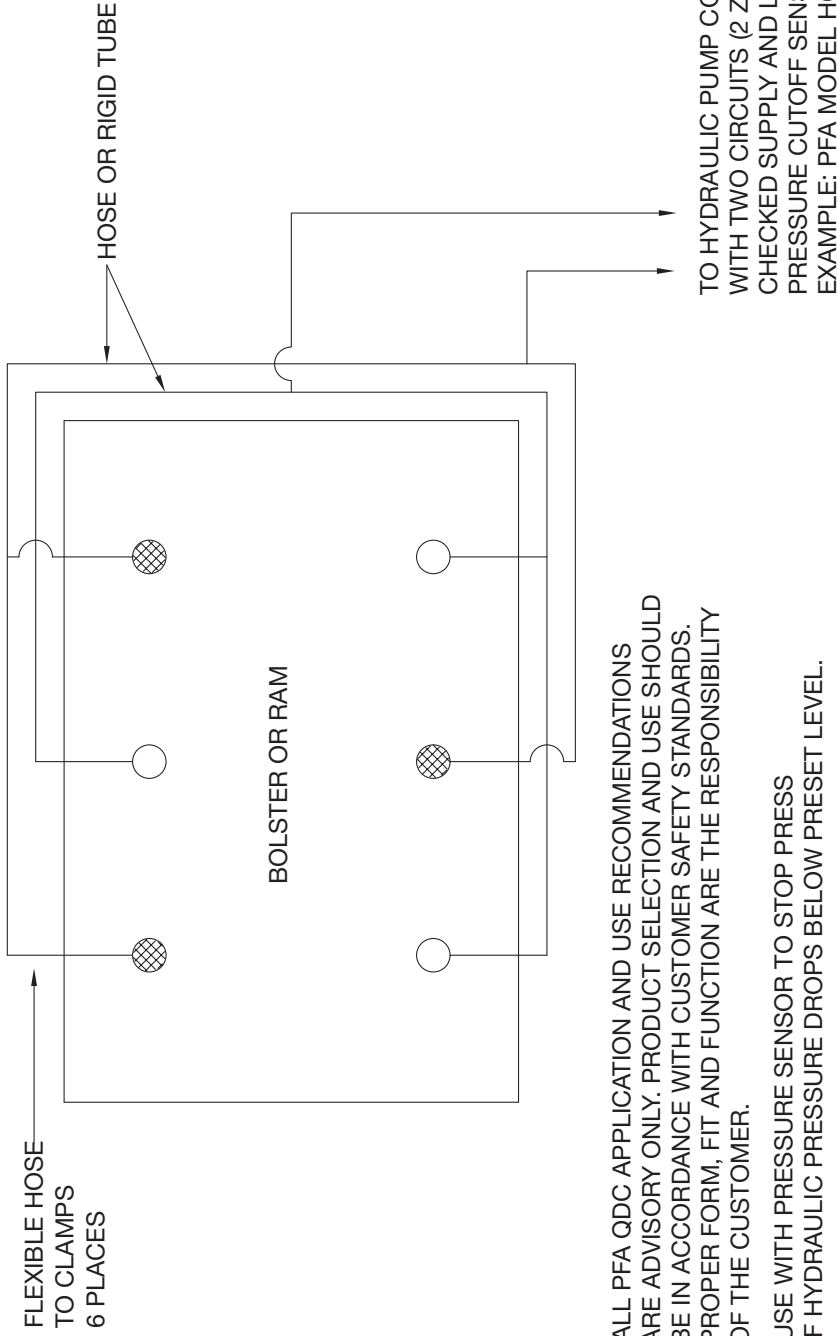

NOTES: UNLESS OTHERWISE SPECIFIED



CLAMPSAFE 1

HYDRO CIRCUITS
DIAGONAL

PAGE 2 OF 3

REV
-

CONFIDENTIAL: The information shown on this sheet is confidential. Permission to use, reproduce or transmit in any way not specifically authorized is expressly withheld.

DISCLAIMER: Illustrative drawings, CAD models, and information described herein is proprietary intellectual property of PFA, Inc., accurate to the company's knowledge at time of printing, and intended for reference only. Specifications are subject to change without notice. If the information obtained from this document is critical to a specific application, it should be confirmed by contacting PFA, Inc. PFA Terms of Sale apply.

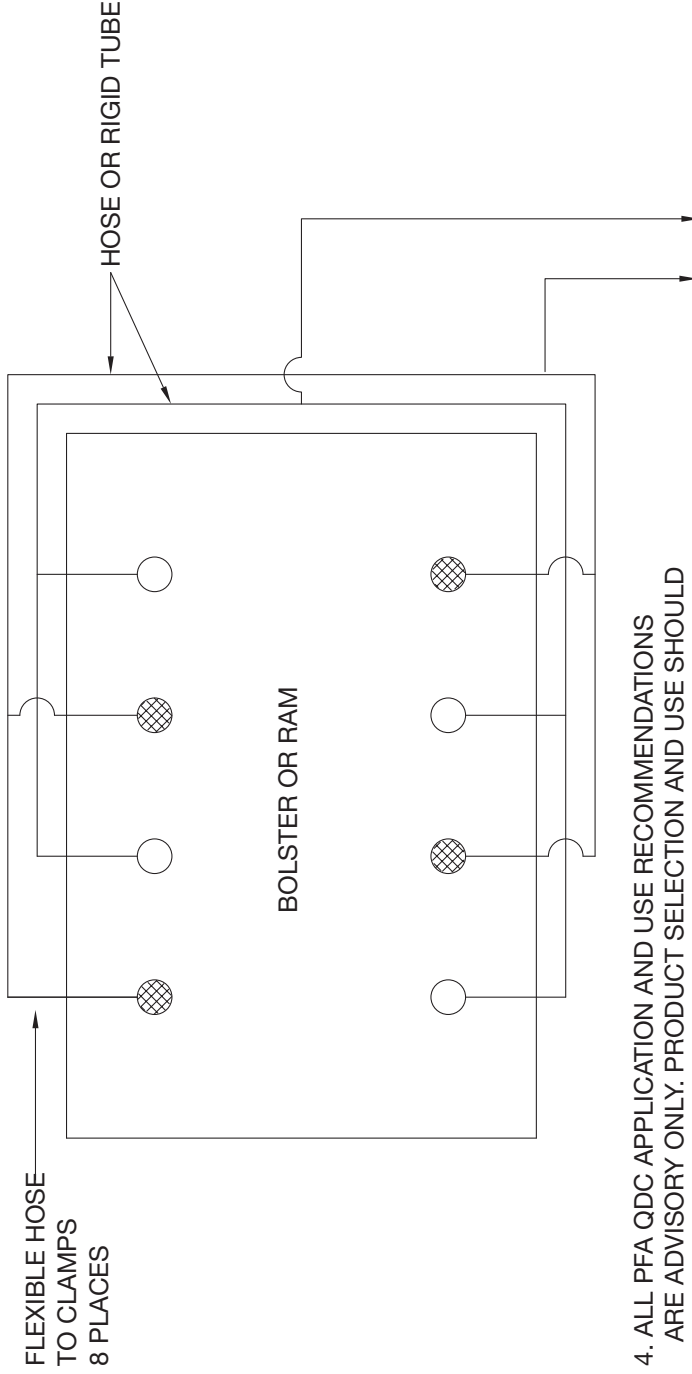

4. ALL PFA QDC APPLICATION AND USE RECOMMENDATIONS ARE ADVISORY ONLY. PRODUCT SELECTION AND USE SHOULD BE IN ACCORDANCE WITH CUSTOMER SAFETY STANDARDS. PROPER FORM, FIT AND FUNCTION ARE THE RESPONSIBILITY OF THE CUSTOMER.

3. USE WITH PRESSURE SENSOR TO STOP PRESS IF HYDRAULIC PRESSURE DROPS BELOW PRESET LEVEL.

2. HYDRAULIC CHECK VALVE LOCATED AT CONTROL VALVE FOR EACH CIRCUIT.

1. CLAMPS POWERED BY INDEPENDENT DIAGONALLY OPPOSITE HYDRAULIC CIRCUITS (ZONES). LOSS OF PRESSURE IN ONE CIRCUIT DOES NOT AFFECT THE OTHERS.

NOTES: UNLESS OTHERWISE SPECIFIED



CLAMPSAFE 1

HYDRO CIRCUITS
DIAGONAL

PAGE 3 OF 3

REV -

CONFIDENTIAL: The information shown on this sheet is confidential. Permission to use, reproduce or transmit in any way not specifically authorized is expressly withheld.

DISCLAIMER: Illustrative drawings, CAD models, and information described herein is proprietary intellectual property of PFA, Inc., accurate to the company's knowledge at time of printing, and intended for reference only. Specifications are subject to change without notice. If the information obtained from this document is critical to a specific application, it should be confirmed by contacting PFA, Inc. PFA Terms of Sale apply.

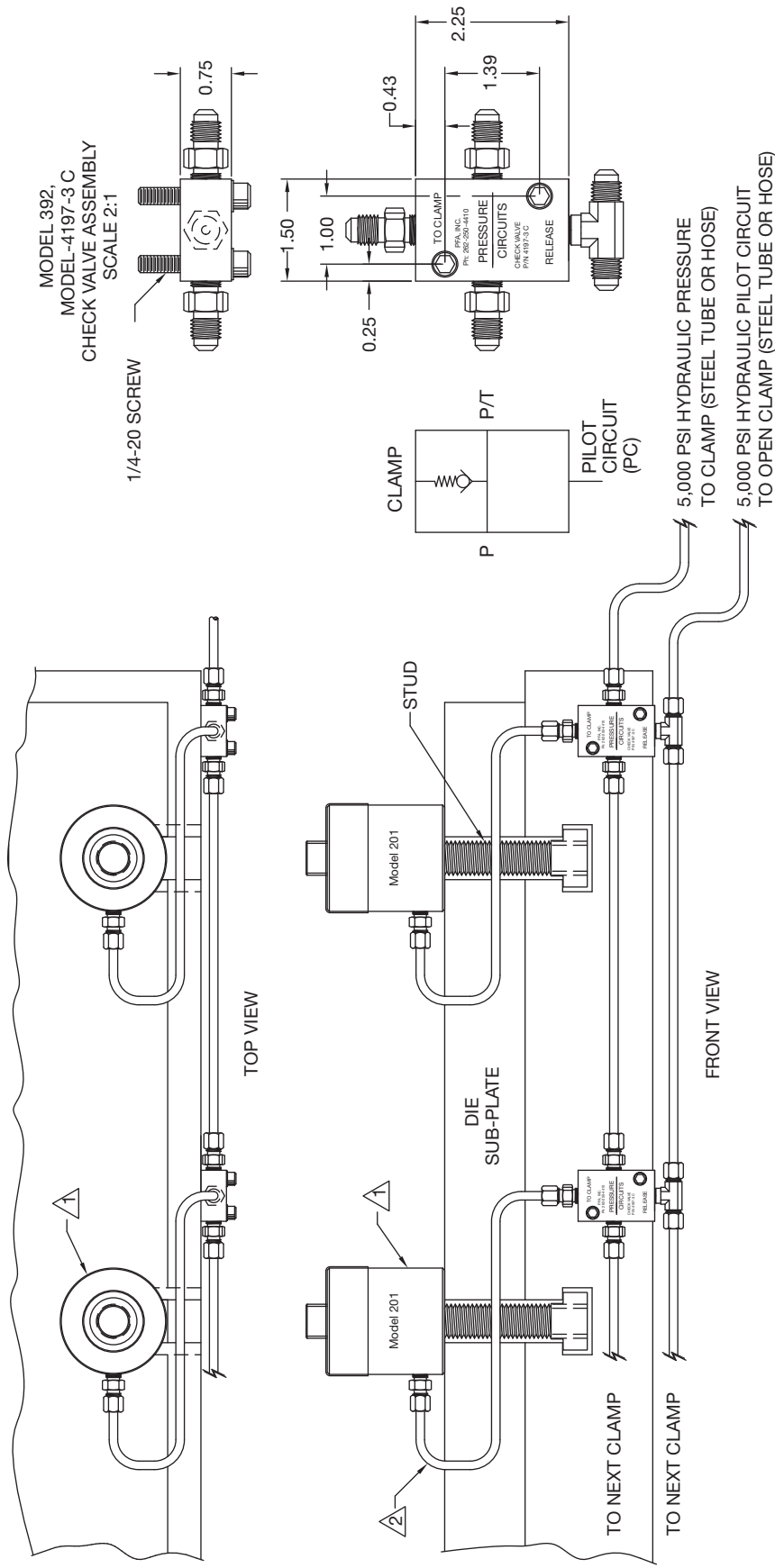

△2 FLEXIBLE HOSE TO CLAMP.

△1 CLAMP SHOWN IN THESE SCHEMATICS IS A MODEL-201 HYDRAULICALLY ACTUATED SPRING RELEASE DESIGN. SCHEMATIC APPLIES TO ALL CLAMPS WITH EXTERNALLY MOUNTED PILOT OPERATED CHECK VALVES.

NOTES: UNLESS OTHERWISE SPECIFIED



CLAMPSAFE 3

HYDRO CIRCUIT
W/ CHECK VALVES

PAGE 1 OF 3

REV -

CONFIDENTIAL: The information shown on this sheet is confidential. Permission to use, reproduce or transmit in any way not specifically authorized is expressly withheld.

DISCLAIMER: Illustrative drawings, CAD models, and information described herein is proprietary intellectual property of PFA, Inc., accurate to the company's knowledge at time of printing, and intended for reference only. Specifications are subject to change without notice. If the information obtained from this document is critical to a specific application, it should be confirmed by contacting PFA, Inc. PFA Terms of Sale apply.

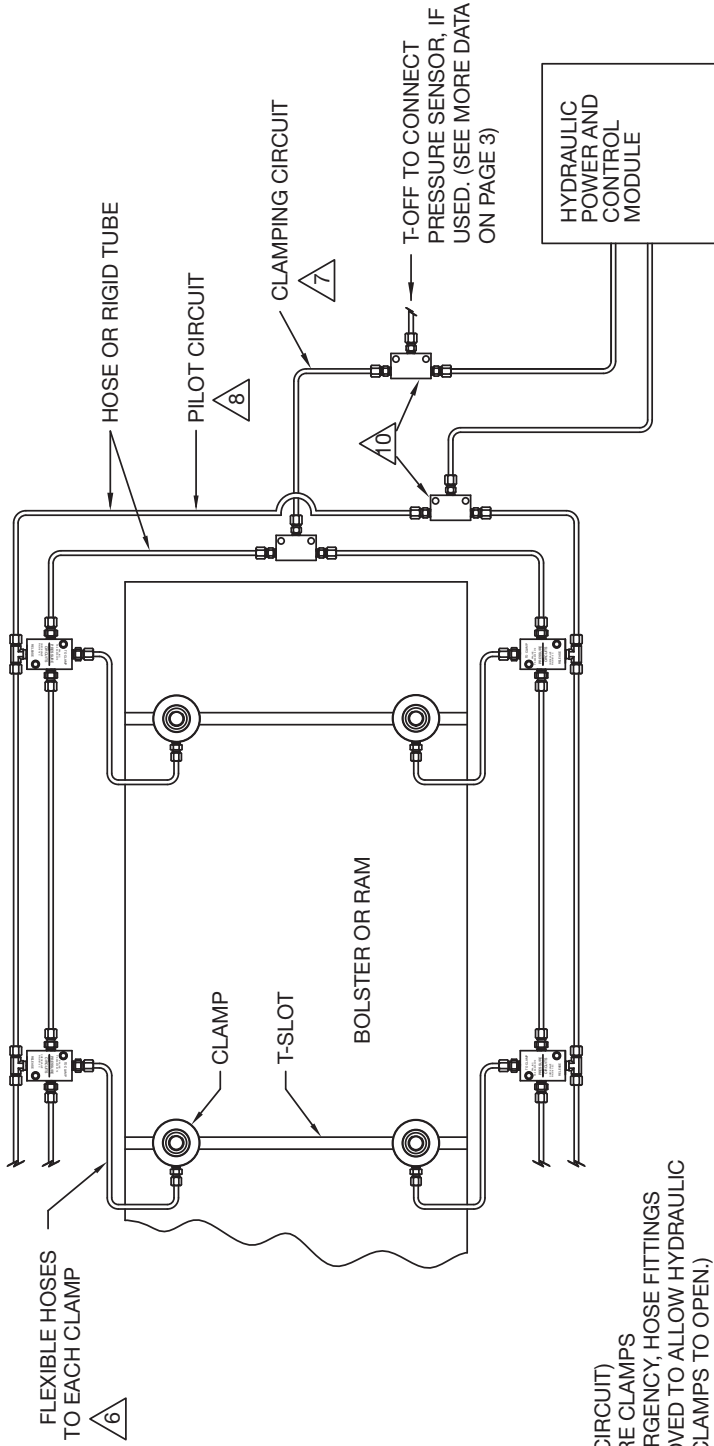

- 8. IF THIS LINE BREAKS (PILOT CIRCUIT) IT MUST BE REPAIRED BEFORE CLAMPS CAN BE OPENED. (IN AN EMERGENCY, HOSE FITTINGS AT CLAMPS COULD BE REMOVED TO ALLOW HYDRAULIC FLUID TO ESCAPE AND THE CLAMPS TO OPEN.)
- 7. IF THIS LINE BREAKS ALL CLAMPS WILL RETAIN CLAMPING PRESSURE. IF INSTALLED, PRESSURE SWITCH WILL STOP PRESS.
- 6. IF THIS HOSE BREAKS THIS CLAMP WILL OPEN BUT ALL OTHER CLAMPS RETAIN CLAMPING PRESSURE. IF INSTALLED, PRESSURE SWITCH WILL SENSE PRESSURE DROP AND STOP PRESS.
- 5. USE WITH PRESSURE SENSOR TO STOP PRESS IF HYDRAULIC PRESSURE DROPS BELOW PRESET LEVEL. PRESSURE SENSOR IS TYPICALLY PROVIDED ON MAIN PRESSURE LINE IN CONTROLLER (PS). PRESSURE SENSORS CAN BE CONNECTED TO INDIVIDUAL CIRCUITS AS DESIRED (SEE PAGE 3).
- 4. NOTE THAT CHECK VALVE IS INSTALLED NEAR EACH CLAMP.
- 3. CLAMPS ARE POWERED BY THE CLAMPING CIRCUIT AND OPENED BY THE PILOT CIRCUIT.

- 10. MANIFOLD P/N 1068 CAN BE INSTALLED ANYWHERE ALONG THE CLAMPING AND RELEASE CIRCUITS.
- 9. ALL PFA QDC APPLICATION AND USE RECOMMENDATIONS ARE ADVISORY ONLY. PRODUCT SELECTION AND USE SHOULD BE IN ACCORDANCE WITH CUSTOMER SAFETY STANDARDS. PROPER FORM, FIT AND FUNCTION ARE THE RESPONSIBILITY OF THE CUSTOMER.

NOTES: UNLESS OTHERWISE SPECIFIED



CLAMPSAFE 3

HYDRO CIRCUIT
W/ CHECK VALVES

PAGE 2 OF 3

REV

-

CONFIDENTIAL: The information shown on this sheet is confidential. Permission to use, reproduce or transmit in any way not specifically authorized is expressly withheld.

DISCLAIMER: Illustrative drawings, CAD models, and information described herein is proprietary intellectual property of PFA, Inc., accurate to the company's knowledge at time of printing, and intended for reference only. Specifications are subject to change without notice. If the information obtained from this document is critical to a specific application, it should be confirmed by contacting PFA, Inc. PFA Terms of Sale apply.

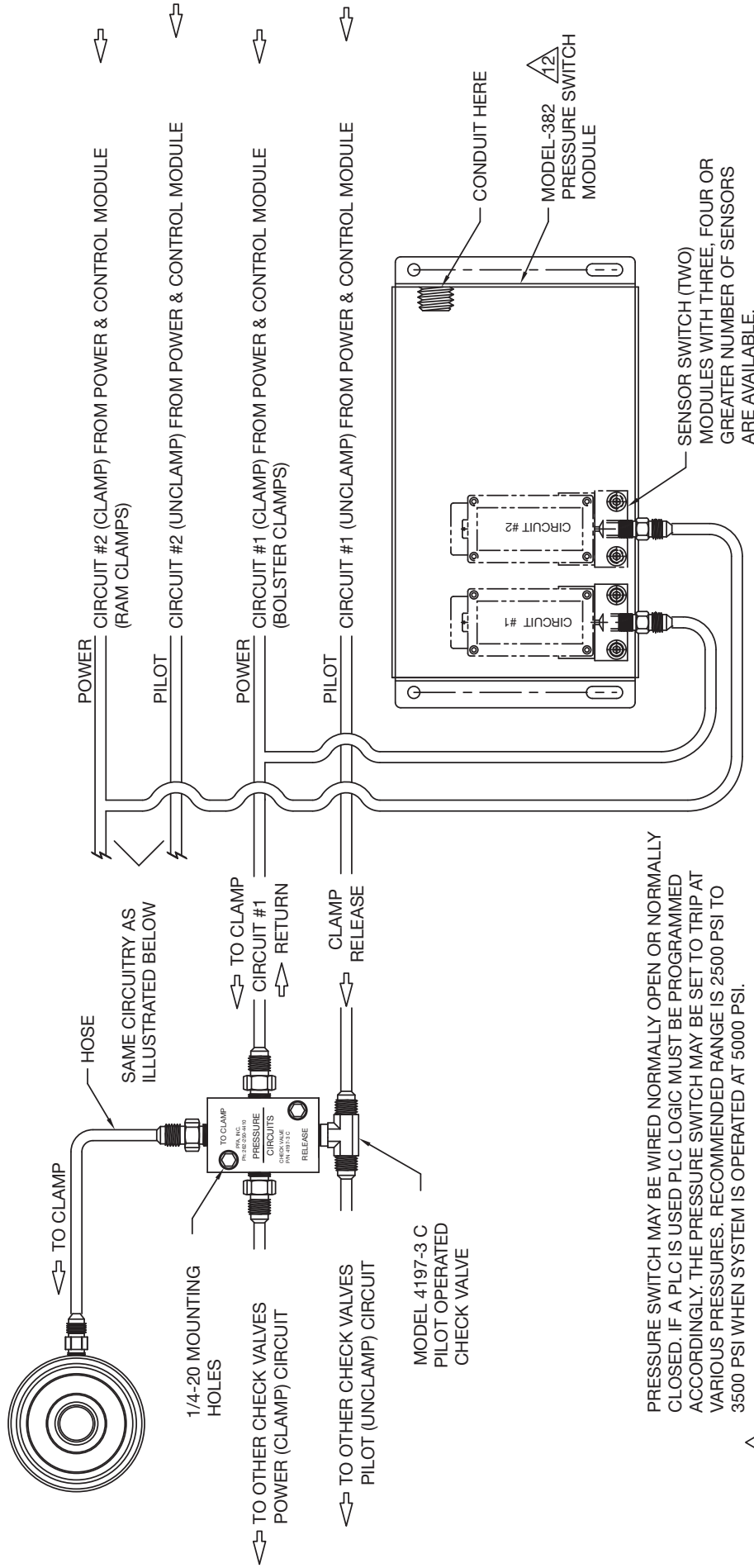

PRESSURE SWITCH MAY BE WIRED NORMALLY OPEN OR NORMALLY CLOSED. IF A PLC IS USED PLC LOGIC MUST BE PROGRAMMED ACCORDINGLY. THE PRESSURE SWITCH MAY BE SET TO TRIP AT VARIOUS PRESSURES. RECOMMENDED RANGE IS 2500 PSI TO 3500 PSI WHEN SYSTEM IS OPERATED AT 5000 PSI.

11. A PRESSURE SWITCH MODULE IS USED WHEN A PRESSURE SENSOR IS INSTALLED ON EACH CIRCUIT, AS DESIRED.

THIS PAGE SHOWS A MODEL 4197-3 C CHECK VALVE INSTALLED WITH A MODEL-201 HYDRAULIC NUT AND OPTIONAL MODEL-382 PRESSURE SWITCH MODULE. TWO SEPARATE CLAMPING AND PILOT CIRCUITS ARE SHOWN (MORE CAN BE ADDED).



CLAMPSAFE 3

HYDRO CIRCUIT
W/ CHECK VALVES

PAGE 3 OF 3

REV -

CONFIDENTIAL: The information shown on this sheet is confidential. Permission to use, reproduce or transmit in any way not specifically authorized is expressly withheld.

DISCLAIMER: Illustrative drawings, CAD models, and information described herein is proprietary intellectual property of PFA, Inc., accurate to the company's knowledge at time of printing, and intended for reference only. Specifications are subject to change without notice. If the information obtained from this document is critical to a specific application, it should be confirmed by contacting PFA, Inc. PFA Terms of Sale apply.

UNLESS OTHERWISE SPECIFIED CHECK VALVE IS SUPPLIED WITH FITTINGS AS SHOWN HERE.

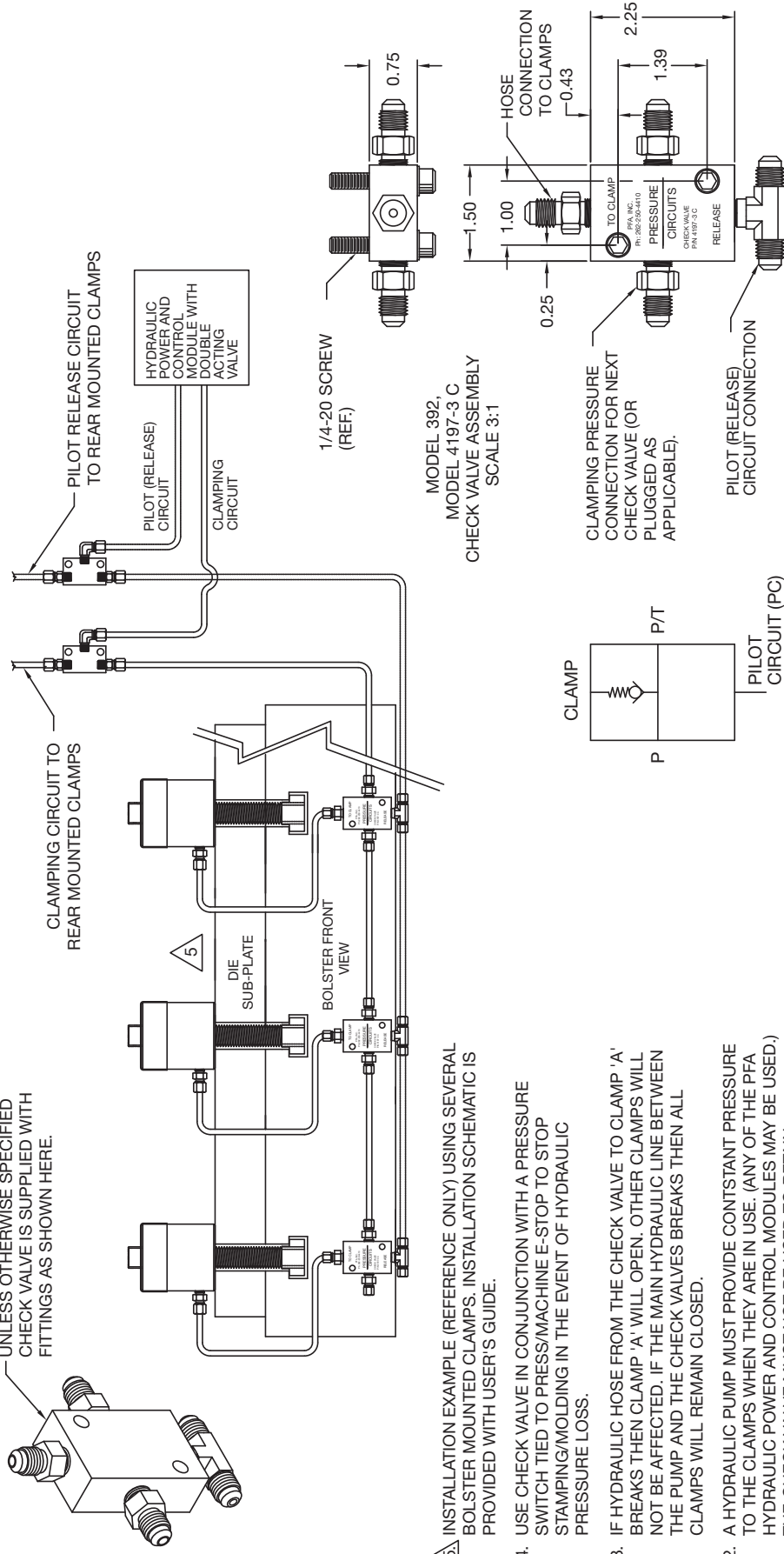

5. INSTALLATION EXAMPLE (REFERENCE ONLY) USING SEVERAL BOLSTER MOUNTED CLAMPS. INSTALLATION SCHEMATIC IS PROVIDED WITH USER'S GUIDE.

4. USE CHECK VALVE IN CONJUNCTION WITH A PRESSURE SWITCH TIED TO PRESS/MACHINE E-STOP TO STOP STAMPING/MOLDING IN THE EVENT OF HYDRAULIC PRESSURE LOSS.
3. IF HYDRAULIC HOSE FROM THE CHECK VALVE TO CLAMP 'A' BREAKS THEN CLAMP 'A' WILL OPEN. OTHER CLAMPS WILL NOT BE AFFECTED. IF THE MAIN HYDRAULIC LINE BETWEEN THE PUMP AND THE CHECK VALVES BREAKS THEN ALL CLAMPS WILL REMAIN CLOSED.
2. A HYDRAULIC PUMP MUST PROVIDE CONSTANT PRESSURE TO THE CLAMPS WHEN THEY ARE IN USE. (ANY OF THE PFA HYDRAULIC POWER AND CONTROL MODULES MAY BE USED.) THE CHECK VALVE MUST NOT BE USED TO RETAIN HYDRAULIC PRESSURE WITHOUT SUCH HYDRAULIC POWER SOURCE BEING CONNECTED.
1. USE THE MODEL-392 HYDRAULIC CHECK VALVE TO AUGMENT HYDRAULIC CLAMPING SAFETY IN QDC AND QMC APPLICATIONS. A PILOT CIRCUIT MUST BE PRESSURIZED IN ORDER TO OPEN THE VALVE. THEREFORE, A CLAMP CHECKED BY THE VALVE CAN NOT OPEN UNTIL THE PILOT CIRCUIT ALLOWS FLUID TO ESCAPE TO PUMP RESERVOIR.

NOTES: UNLESS OTHERWISE SPECIFIED



392/4197-3 C HYDRAULIC CHECK VALVE

ITEM 392

PAGE 1 OF 1

REV -