

MODEL 200L HYDRAULIC CLAMP

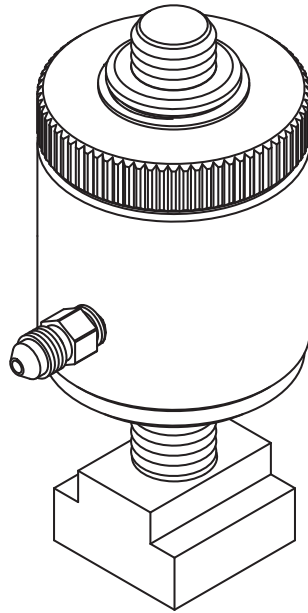

The Model-200L Clamp generates 10,000 of clamping force at 5,000 psi. It is used with dies having slotted underplates, "ears" or "pockets" in line with T-Slots. The clamp is hydraulically actuated and usually mechanically locked during stamping operations.



N118 W18251 Bunsen Drive
Germantown, WI 53022
(262) 250-4410 • Fax (262) 250-4409

pfa-inc.com

TABLE OF CONTENTS

- 1. Installation 3
- 2. Operation 3
- 3. Maintenance 4
- 4. Seal Replacement Procedure 4
- 5. Recommended Spare Parts 4
- 6. Drawings 5
 - DWG-200L
 - DWG-200LPD

WARNING

USE SAFETY GEAR AT ALL TIMES – SYSTEM MAY EJECT HYDRAULIC FLUID AT ANY TIME.
Read this complete User Guide and study Drawings 200L and 200LPD before proceeding.

Hydraulic plumbing on press/machine depends on the type of clamps used, hydraulic clamping safety employed and other devices, which are connected to the system. Determination of application Safety and Safe Operation is the user’s responsibility.

INSTALLATION

1. Place T-Nut in T-Slot and make sure that the T-Nut is sized correctly.
2. Verify that the stud length is correct.
3. Rotate the stud so that the proper die grip height is achieved. The stud must be fully engaged in the clamp.

Study DWG-200L attached carefully. Make sure that the die grip height for the various dies are within the dimensions noted on DWG-200L.
4. Place the clamp in the T-Slot and connect hydraulic hose. Note that the hydraulic hose will prevent the clamp from rotating. (If the clamp is rotated then the clamping height is changed).

OPERATION

Note: Integrate the following steps into your die exchange procedure.

1. **TO INSTALL DIE.** Connect Hydraulic Power Supply (HC) to system if using a Carriable/Removable Pump Controller.
2. Activate Lift of Die Lifters (if any), Place die in press, and lower die lifters (if any).
3. Move bolster mounted clamps to proper clamping position and activate the proper hydraulic circuit to clamp lower clamps.
4. Make required adjustments and move slide down to upper die.
5. Move ram mounted clamps to proper clamping position and activate the proper hydraulic circuit to clamp upper clamps.
6. Set all mechanical locks (upper and lower) by rotating the lock nuts (item 10 on Drawing 200LPD) manually until they are firmly in contact with the clamp housing. Clamps are now mechanically locked in the clamp position.
7. Deactivate hydraulics, Confirm clamps remain clamped and Locked, and Disconnect Hydraulic Power Supply (HC) if using Carriable/Removable Pump Controller (if desired).
8. **TO REMOVE DIE,** Move slide to proper down position for die exchange.
9. Connect Hydraulic Power Supply (HC) to system. Apply Hydraulic Clamp pressure to all clamps.
10. Press Hydraulic Booster Button (HM) to boost pressure above initial clamp pressure to loosen Nuts.
11. Turn Lock Nuts away from clamp housing.
12. Release hydraulic pressure to all clamps to allow clamps to open.
13. Move clamps away from die.
14. Jog ram up.
15. Activate die lifters, if any, to lift die.
16. Perform die exchange.

CAUTION: Use only dies with U slots, Aears® or pockets, i.e., clamping surfaces which support the clamp on opposite sides of the stud. Make sure that the clamp surface thickness die grip height is within the range of the clamp.

MAINTENANCE

1. Periodically check hoses for signs of wear.
2. Replace hoses if necessary.
3. Examine clamp for damage.
4. Check mechanical locking nuts for ease of operation.
5. Chase any damaged threads if necessary.
6. Check for hydraulic leaks. Tighten fittings or replace hoses as necessary.
7. See enclosed for seal replacement procedures.
8. If a pipe thread fitting is removed, apply new thread tape before reassembling fitting.
9. If stud is replaced, use grade B7 threaded Rod or Forged High Strength Alloy Steel with Minimum Tensile strength 125,000 psi or grade 8 or similar. PFA replacement parts are recommended for proper operation.
10. If T-nut is replaced make sure that it is securely fastened to the stud. Apply permanent thread locking compound IAW manufacturer's recommendations.

SEAL REPLACEMENT PROCEDURE

1. Obtain copy of drawing 200LPD, copy attached. Note position of all components.
2. If seals are to be replaced obtain the two seals and lubricant specified on drawing 200LPD.
3. If Connector, P/N 1804-1 is removed, apply teflon thread tape before re-installation. Apply proper pipe fitting torque.
4. To disassemble clamp start by removing spiral retaining ring P/N 3688 and locking nut P/N 3686. Then depress spring retainer P/N 3683 and remove retaining ring P/N 3687.
5. Separate the piston from the housing. Place the clamp housing in a soft jaws vise and pull the piston out. (Thread a stud into the piston and pull the assembly out).
6. Remove spring retainer, spring guide and spring as shown in drawing 200LPD.
7. Remove the two seals and discard.
8. Clean parts if required.
9. Apply magna-lube in seal (O'ring) grooves and on the seals.
10. Carefully install seals on piston as shown Page 2 of drawing 200LPD. The seals must be oriented as shown.
11. Carefully insert piston into clamp housing. Be careful to avoid seal damage.
12. Install spring guide, springs and spring retainer as shown in drawing 200LPD.
13. Depress spring retainer and install retaining ring. Make sure that the retaining ring is fully seated in groove.
14. Install locking nut and spiral retaining ring.
15. Apply hydraulic pressure and check for leaks.

RECOMMENDED SPARE PARTS

Please refer to parts contained in Seal Replacement Kit 200LPD-SEAL and Refurbish Kit Part #200LPD-RFB as shown on DWG 200LPD.

DISCLAIMER: Illustrative drawings, CAD models, and information described herein is proprietary intellectual property of PFA, Inc., accurate to the company's knowledge at time of printing, and intended for reference only. Specifications are subject to change without notice. If the information obtained from this document is critical to a specific application, it should be confirmed by contacting PFA, Inc. PFA Terms of Sale apply.

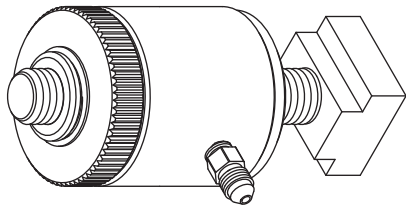

MODEL-200L

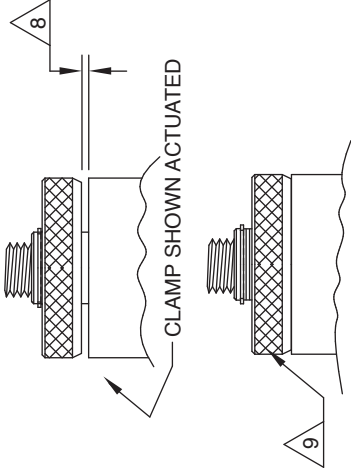

CLAMP SHOWN ACTUATED

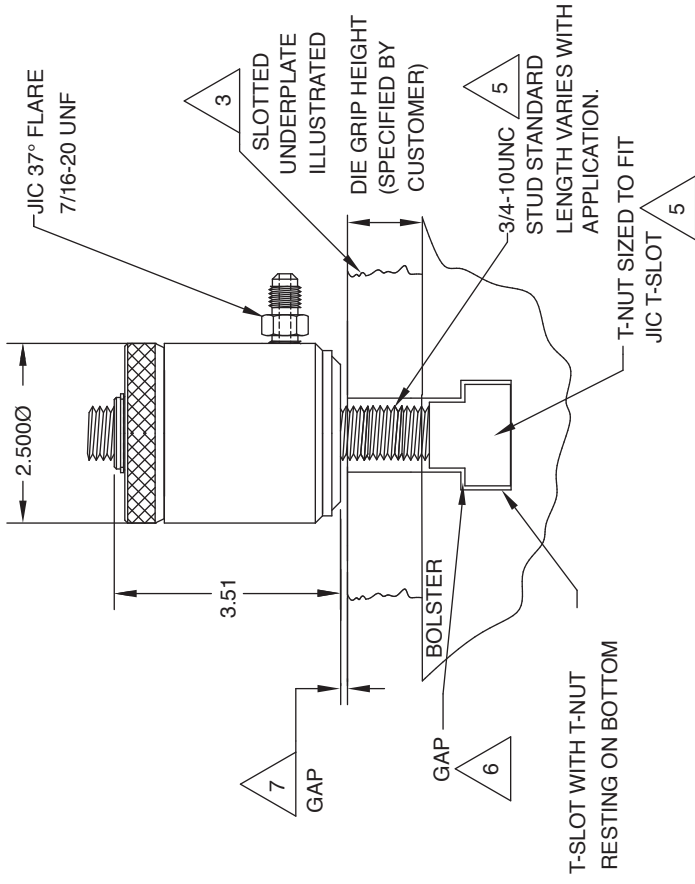

T-SLOT WITH T-NUT RESTING ON BOTTOM

- 9 AFTER CLAMP ACTUATION THE MECHANICAL LOCK MUST BE FIRMLY HAND TIGHTENED (NO WRENCHES) AGAINST THE CLAMP BODY. THE HYDRAULIC PRESSURE CAN THEN BE DISCONNECTED. THE HYDRAULIC PRESSURE MUST BE APPLIED IN ORDER TO OPEN THE MECHANICAL LOCK.
- 8 THIS DIMENSION (THE MECHANICAL LOCK WAS TOUCHING THE CLAMP BODY AT THE TIME OF ACTUATION) SHOWS THE AMOUNT OF PISTON TRAVEL WHICH WAS NECESSARY TO PRELOAD THE STUD TO 10,000 LBS CLAMPING FORCE.
- 7 ALWAYS KEEP THE GAP BETWEEN THE DIE AND THE CLAMP BODY TO A MINIMUM. (IF NECESSARY REMOVE THE CLAMP FROM THE T-SLOT AND SCREW THE STUD INTO THE CLAMP FOR A CLOSE FIT.) THE CLAMP STROKE WHICH IS .29 MUST BE SUFFICIENT TO CLOSE THE GAP 6 AND 7 AND PRE-LOAD THE STUD TO 10,000 LBS CLAMPING FORCE.
- 6 THE T-NUT SHOULD BE SIZED TO MINIMIZE THIS GAP YET ALLOW THE CLAMP TO MOVE FREELY IN THE T-SLOT.
- 5 T-SLOT SIZE AND DIE GRIP HEIGHT ARE USED TO SELECT T-NUT AND STUD LENGTH.
- 4 AVAILABLE WITHOUT MECHANICAL LOCK. (MODEL-200)
- 3 USE WITH DIES HAVING 'EARS', 'POCKETS' OR SLOTTED UNDERPLATES.
- 2 CLAMPING FORCE: 10,000 LBS @ 5000 PSI
- 1 THE MODEL-200L IS A HYDRAULIC NUT STYLE CLAMP WITH A MECHANICAL LOCK WHICH OPERATES AT 5000 PSI MAXIMUM HYDRAULIC PRESSURE.

NOTES: UNLESS OTHERWISE SPECIFIED.



200L HYDRAULIC CLAMP-LOCKING

ITEM 200L

PAGE 1 OF 1

REV

CONFIDENTIAL: The information shown on this sheet is confidential. Permission to use, reproduce or transmit in any way not specifically authorized is expressly withheld.

DISCLAIMER: Illustrative drawings, CAD models, and information described herein is proprietary intellectual property of PFA, Inc., accurate to the company's knowledge at time of printing, and intended for reference only. Specifications are subject to change without notice. If the information obtained from this document is critical to a specific application, it should be confirmed by contacting PFA, Inc. PFA Terms of Sale apply.

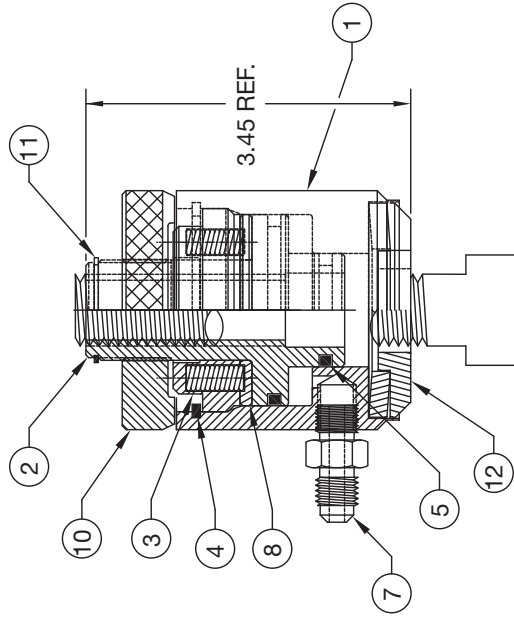
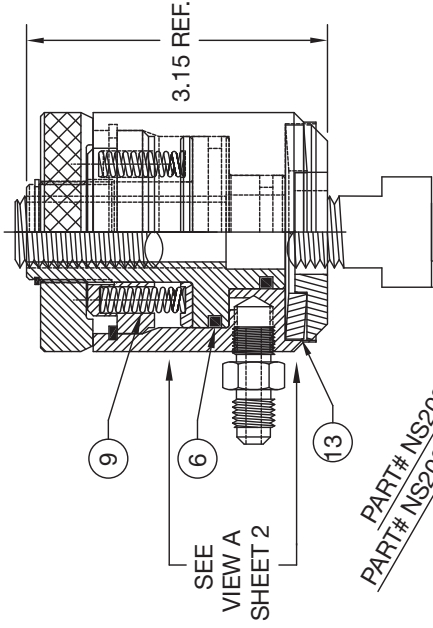

ITEM	DESCRIPTION	PART NUMBER
1	200LUG	
1	MAGNALUBE, TUBE (NOT SHOWN)	ZZ36120
1	LABEL, LOCK-UNLOCK	2907-2
1	LABEL, PFA (NOT SHOWN)	1075
1	SPRING, BELLEVILLE	1768
1	CAP, SPRING	3015
1	RETAINING RING, SPIRAL	3688-16 RG00076
1	NUT, LOCKING, 1-1/16UN	3686
8	SPRING, COMPRESSION, .2580	3716
1	SPRING GUIDE	3715
1	FITTING, 1/8 MALE, 37°	1804-1
1	HIGH PRESSURE SEAL, 2.00 OD	3701 PI92001
1	HIGH PRESSURE SEAL, 1.18 OD	3700 PI92000
1	RETAINING RING, SPIRAL, 1.18 OD	3687 RG00070
1	SPRING RETAINER	3683
1	PISTON, HYD NUT, 200 SERIES	3685 NK00012
1	HOUSING, HYDRAULIC NUT	3684

5 APPLY MAGNA-LUBE 'G' TO SEALS AND MOVING PARTS WHEN ASSEMBLING.

4 NOTE SEAL ORIENTATION (CRITICAL) (SEE SHEET 2)

3 THIS COLUMN SHOWS PARTS INCLUDED IN REFURBISH KIT (PART# 200LPD-RFB)

2 THIS COLUMN SHOWS PARTS INCLUDED IN SEAL KIT (PART# 200LPD-SEAL)

1 THIS COLUMN SHOWS PARTS INCLUDED IN BASIC MODEL-200L CLAMP (REFERENCE ONLY)



200LPD HYDRAULIC CLAMP-LOCKING

ITEM 200L

PAGE 1 OF 2

REV -

CONFIDENTIAL: The information shown on this sheet is confidential. Permission to use, reproduce or transmit in any way not specifically authorized is expressly withheld.

DISCLAIMER: Illustrative drawings, CAD models, and information described herein is proprietary intellectual property of PFA, Inc., accurate to the company's knowledge at time of printing, and intended for reference only. Specifications are subject to change without notice. If the information obtained from this document is critical to a specific application, it should be confirmed by contacting PFA, Inc. PFA Terms of Sale apply.

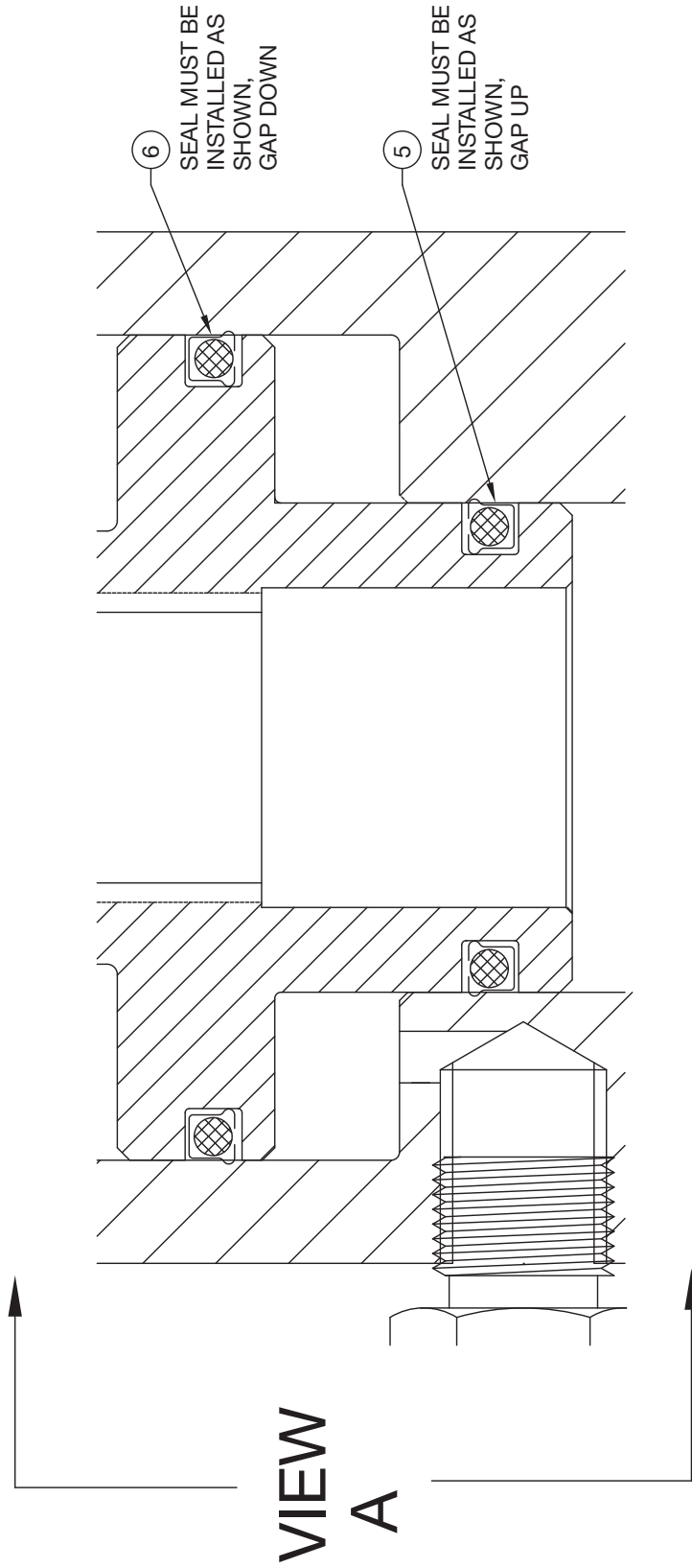

200LPD HYDRAULIC CLAMP-LOCKING

ITEM 200L

PAGE 2 OF 2

REV

-